

TI2005-400

Cobra 400 Hz Aviation Plug



Power Anytime, Anywhere

The Tesla™ Cobra 400 Hz Aviation Plug is constructed from a rugged combination of advanced composite materials and corrosion-resistant alloys. The result is a waterproof 400 Hz aviation plug that will withstand battlefield conditions and other extreme environments. This virtually indestructible design, along with highly conductive contact materials and fast “in-the-field” component replacement make it the last 400 Hz aviation plug you will ever need.

Features:

- Rated to 3000 peak amps
- Clamped cable connections
- UV, fuel, fungus, and oil resistant
- Easy component replacement
- Manufactured in-house
- Exceeds MIL-STD-810
- Tested to withstand 50 G of force



Tesla™ Industries, Inc.

www.teslaind.com ♦ www.tesla1.com

Email: tesla1@teslaind.com

Headquarters: (302) 324-8910

101 Centerpoint Blvd. New Castle, DE 19720

Western Regional Office: (775) 622-8801

9475 Double R Blvd. Suite 2, Reno, NV 89521



The POWER
Of
RED™



Features and Benefits

Weatherproof Construction

Through a series of strategically placed seals and bushings, the Cobra™ 400 Hz Aviation Plug is hermetically sealed to lock out rain, snow, sand and other harmful debris.

Internal Cable Connections

Unlike connectors with cables molded directly into the housing, easily accessible lugs allow for direct termination inside of the plug. Additionally, compression grommets and bushings provide strain relief. This unique combination of protection eliminates dangerous shocks from exposed wiring due to cable stretching and splicing.

Rugged, Durable, Reliable

Made from virtually indestructible composite materials, the plug housing won't crack, melt, blister, dry-rot or disintegrate. This, in conjunction with corrosion resistant conductors, insures that the Cobra™ 400 Hz Aviation Plug will still be in the field long after other plugs have failed.

Replaceable Contacts

Manufactured from highly conductive alloys, the contacts are specially tapered and have memory to maximize contact surface area and to minimize deformity over time. Once installed, contacts are hermetically sealed within the plug.

Insertion/Extraction Tool

The Cobra™ 400 Hz Aviation Plug can be easily repaired by replacing the contacts using the Insertion/Extraction Tool. The tool and replacement contacts can be ordered through Tesla™ Customer Service at (302) 324-8910.



Replaceable Nose: TI2004-340



REPLACING NOSE on 400Hz:

1. Remove screws using 5/32" hex key turning counterclockwise.
2. Put aside the screws and lock washers.
3. Line up and insert new Replaceable Nose ([TI2004-340](#)). Make sure the flat side is against the plug. (Printed letters facing out)
4. Screw in the two screws clockwise.

Components - Exploded View

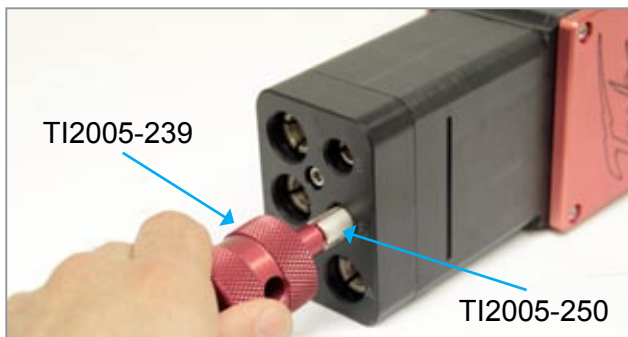
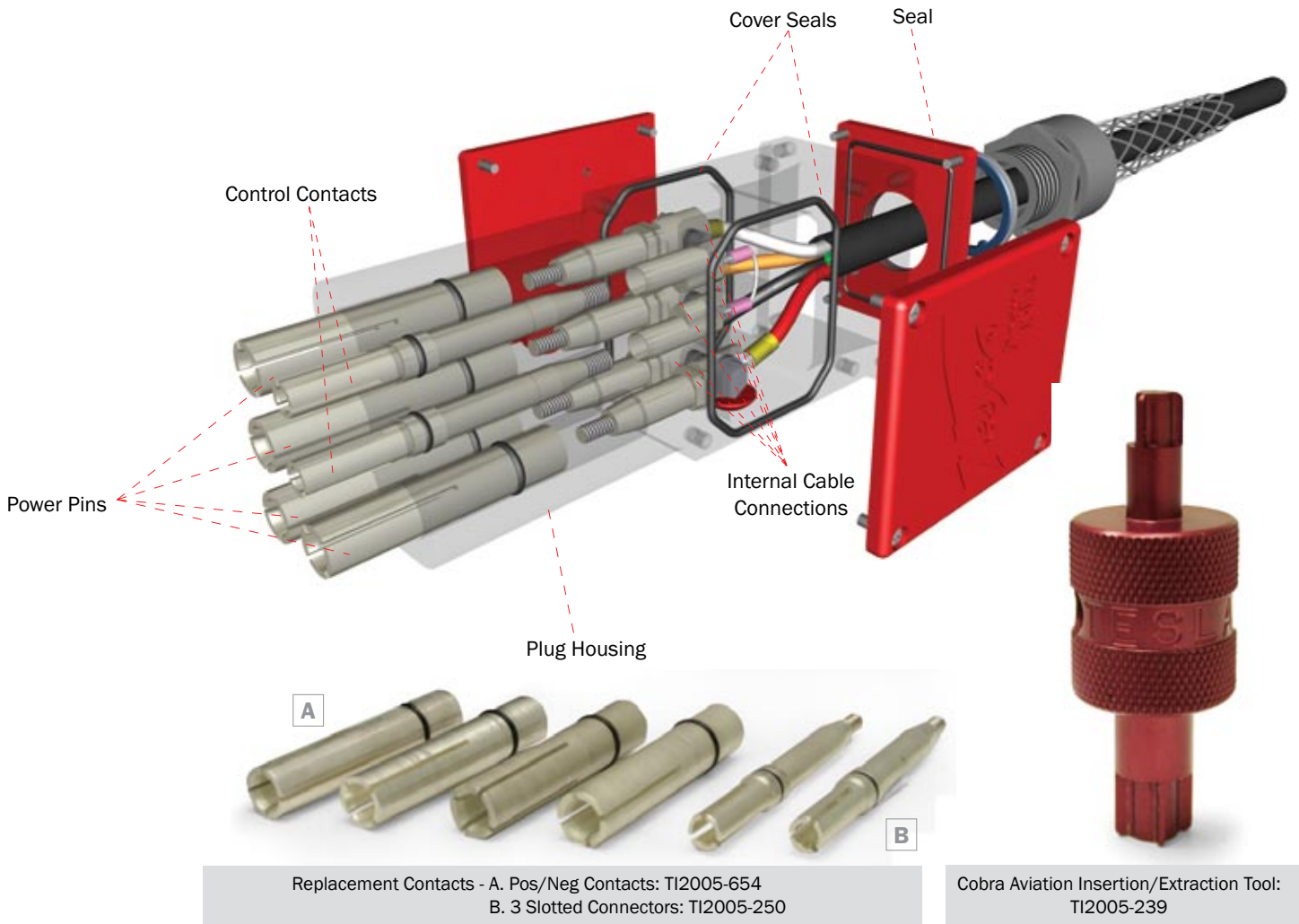

REPLACING CONTROL PIN:

1. Use Insertion/Extraction Tool (TI2005-239) using the smaller end to remove the pin by inserting and turning counterclockwise.
2. Apply the Silicone Compound (TI6000-367) to the male threads of the replacement pin.
3. Install new pin (TI2005-250) using same tool and screw in the clockwise.

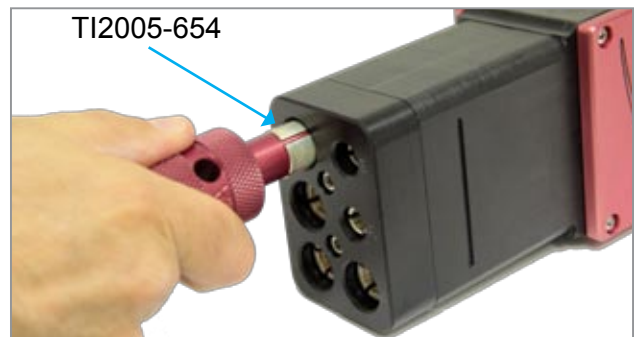

REPLACING POWER PIN:

1. Use Insertion/Extraction Tool (TI2005-654) using the larger end to remove the pin by inserting and turning counterclockwise.
2. Apply the Silicone Compound (TI6000-367) to the male threads of the replacement pin.
3. Install new pin (TI2005-251) using same tool and screw in the clockwise.

Dimensions and Technical Specifications

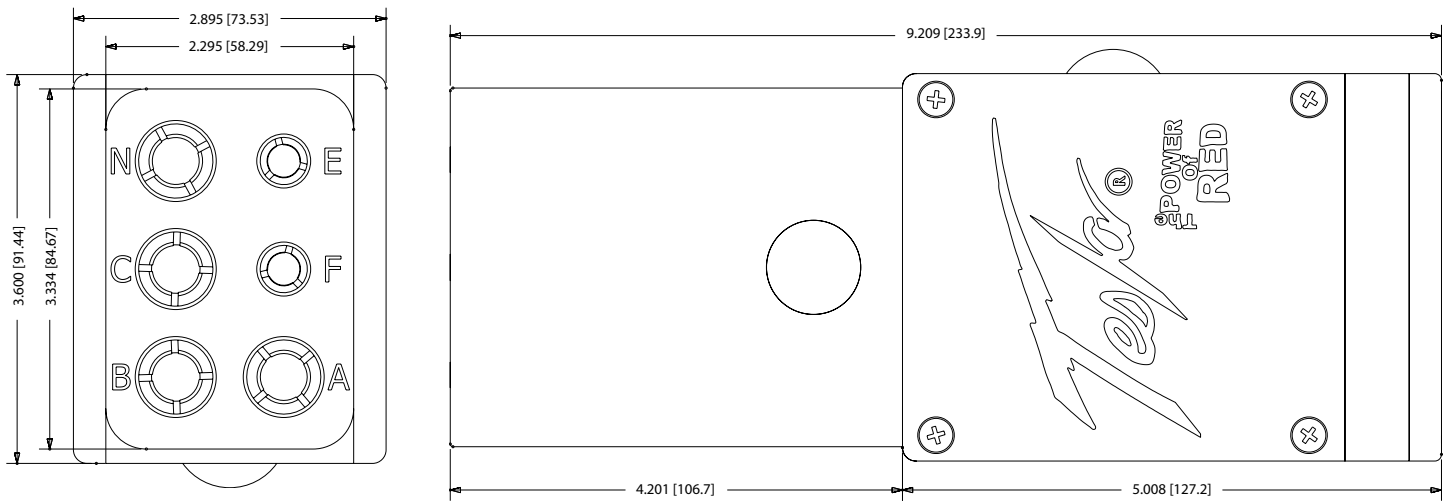

* All dimensions are in inches [millimeters]



Technical Specifications:

Number of Contacts	6
Terminal Lugs	3/8 - 24 (power pins)
Peak Current	3000 A (power pins)
Storage Temperature	-65 °C - 125 °C (-85 °F - 257 °F)
Operating Temperature	-40 °C - 110 °C (-40 °F - 230 °F)
Air Gap-leakage Path	0.630" (16 mm)
Protection Class	IP28C (tested to 20 m)
Rated Current	1500 A
Rated Voltage	100 - 264 VDC
Dielectric Strength	> 6000 VDC for 1 min. across contacts
Insulation Resistance	4 GΩ w/1 kV across contacts
Contact Resistance	< 60 μΩ @ 25 °C
Shock	50 G
Vibration	MIL-STD-810
Engagement Torque	25 lbs (11.33 kg)
Weight	4.5 lbs (2.04 kg)
Warranty	2 years (3 years optional)

