

TI2005-129

Cobra Compact NATO Plug

NSN: 5935-01-523-8368



Power Anytime, Anywhere

The Tesla™ Cobra Compact NATO Plug fits into tight spaces, yet can handle as much power as a full-size Tesla™ Cobra NATO Plug. Constructed from a rugged combination of advanced composite materials and corrosion-resistant alloys, the NATO plug will withstand the harshest battlefield conditions and other extreme environments. Along with highly conductive contact materials, the virtually indestructible design and fast “in-the-field” component replacement make it the last NATO plug you will ever need. New positive post with tip to prevent arcing when connecting when power is on.

Features:

- Rated to 3000 peak amps
- Clamped cable connections
- UV, fuel, fungus, oil, and water resistant
- Easy component replacement
- Tested to withstand 50 G of shock
- Exceeds MIL-STD-810
- Manufactured by Tesla™
- 2 Year Warranty



Tesla™ Industries, Inc.

www.teslainsd.com ♦ www.tesla1.com

Email: tesla1@teslainsd.com

Headquarters: (302) 324-8910

101 Centerpoint Blvd. New Castle, DE 19720

Western Regional Office: (775) 622-8801

9475 Double R Blvd. Suite 2, Reno, NV 89521



The POWER
Of
RED™



Features and Benefits

Weatherproof Construction

Through a series of strategically placed seals and bushings, the Cobra Compact NATO Plug is hermetically sealed to lock out rain, snow, sand and other harmful debris.

Internal Cable Connections

Unlike plugs with cables that are molded directly to the housing, easily accessible lugs allow for direct termination inside of the plug. Additionally, compression grommets and bushings provide strain relief. This unique combination of protection eliminates dangerous shocks from exposed wiring due to cable stretching and splicing.

Rugged, Durable, Reliable

Made from virtually indestructible composite materials, the plug housing won't crack, melt, blister, dry-rot or disintegrate. This, in conjunction with corrosion resistant conductors, insures that the Tesla™ Compact NATO Plug will still be in the field long after other plugs have failed.

Replaceable Contacts

Manufactured from highly conductive alloys, the negative contact is specially tapered and has memory to maximize contact surface area and to minimize deformity over time. Once installed, contacts are hermetically sealed within the plug.

Insertion/Extraction Tools

Contacts can be easily replaced “in-the-field” without discarding the entire plug using the Insertion/Extraction Tools. The tools and contact replacements can be ordered through Tesla™ Customer Service at (302) 324-8910.



Figure 1: Hermetically sealed & easily replaceable contacts



A. Negative Insertion/Extraction Tool: TI2005-126
NSN: 5120-01-523-8761

B. Negative Contact: TI2005-121 NSN: 5999-01-525-0582

C. Positive Post: TI2004-4444

Components - Exploded View

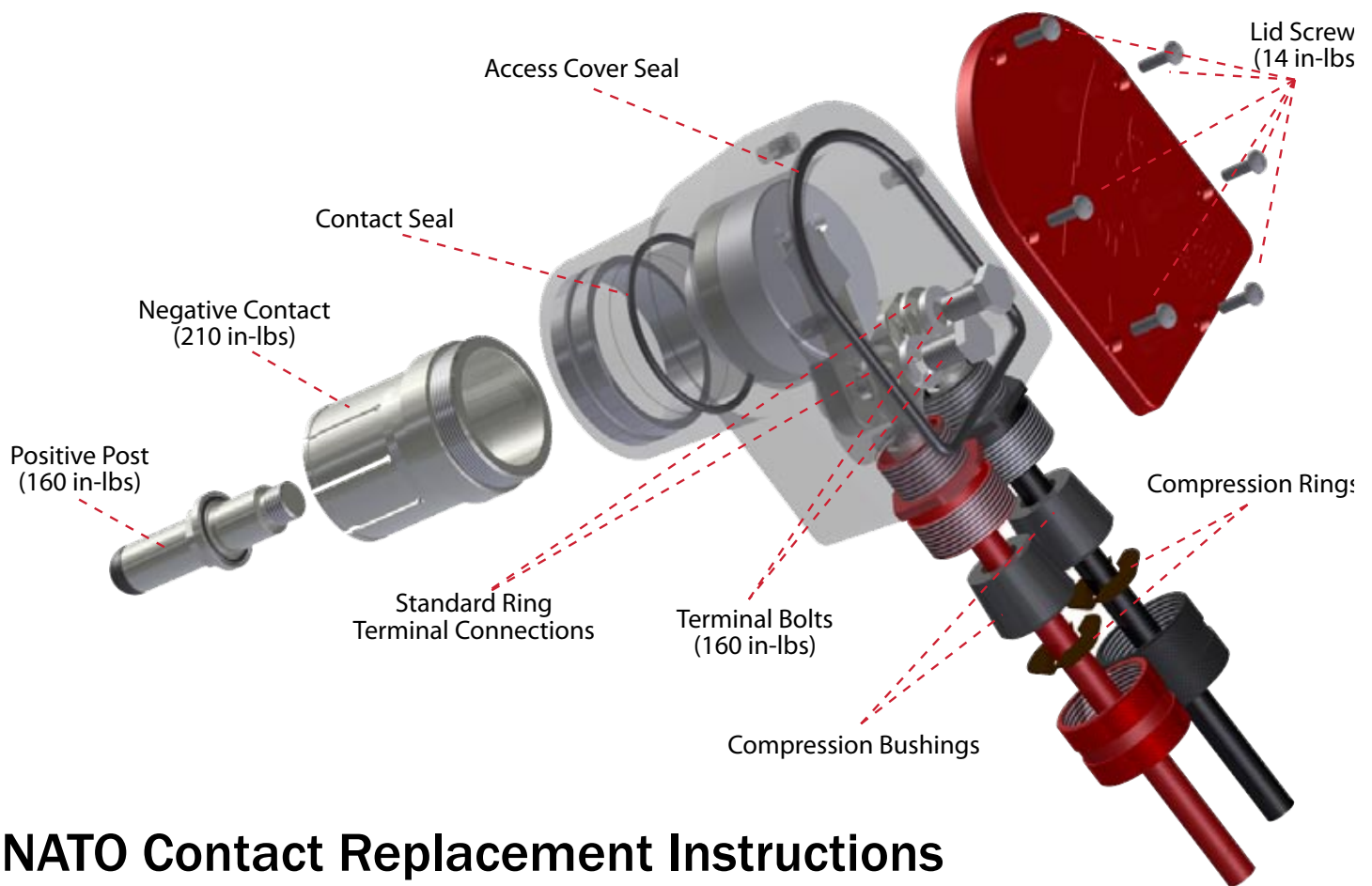

NATO Contact Replacement Instructions



REPLACING NEW STYLE POSITIVE POST:

1. Use a 3/4" Deep Well Socket to remove the positive post by inserting and turning counterclockwise.
2. Apply the Silicone Compound (TI6000-367) to the male threads of the new positive post.
3. Install new positive post (TI2004-444) using same tool and screw in the contact clockwise.

NOTE: TI2004-444 post can only be installed in new style NATO Plugs. This is indicated with a post that has a black tip on the end.

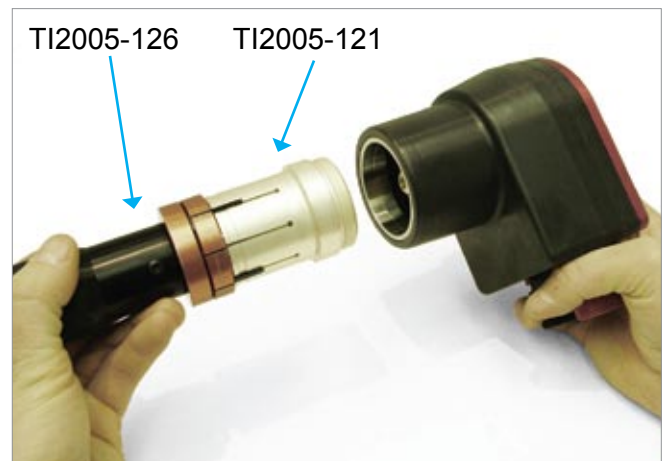

REPLACING NEGATIVE CONTACT:

1. Use the Negative Contact Tool (TI2005-126) to remove old negative contact by inserting and turning counter-clockwise.
2. Apply the Silicone Compound (TI6000-367) to the male threads of the negative contact.
3. Install new negative contact (TI2005-121) and screw in the contact clockwise.

Dimensions and Technical Specifications

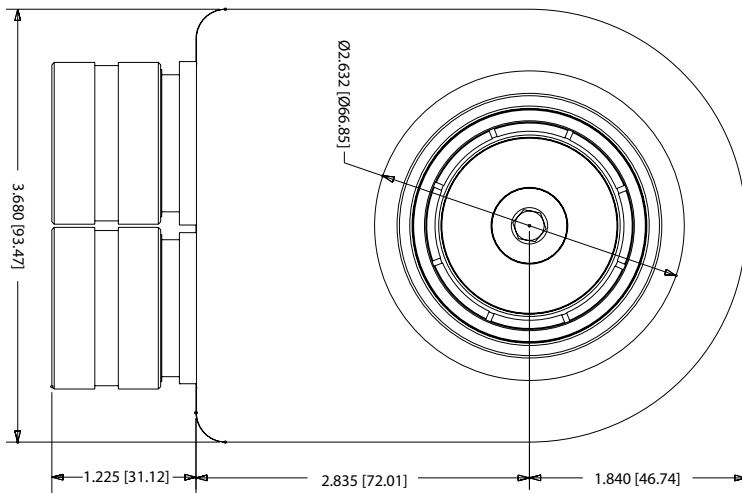

* All dimensions are in inches [millimeters]

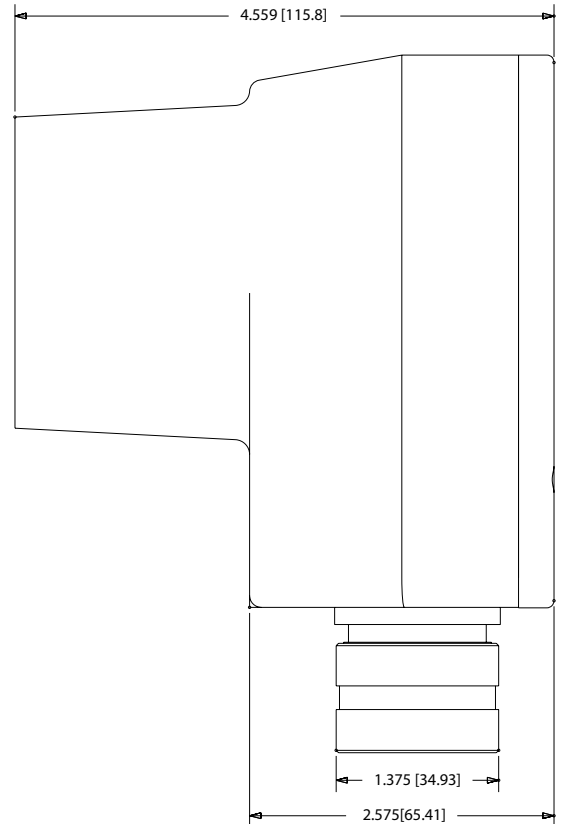

Technical Specifications:

Number of Contacts	2
Terminal Lugs	3/8-24
Peak Current	3000 A
Storage Temperature	-65 °C - 125 °C (-85 °F - 257 °F)
Operating Temperature	-40 °C - 110 °C (-40 °F - 230 °F)
Air Gap-leakage Path	0.355" (9 mm)
Protection Class	IP28C (tested to 20 m)
Rated Current	1500 A
Rated Voltage	18 - 32 Vdc
Inrush Current (@ 28 Vdc)	3000 A
Dielectric Strength	> 6000 Vdc for 1 min. across contacts
Insulation Resistance	4 G Ω w/1 kV across contacts
Contact Resistance	< 50 $\mu\Omega$ @ 25 °C
Shock	50 G
Vibration	MIL-STD-810
Engagement Torque	45 lbs (20.5 kg)
Weight	3.60 lbs (1.64 kg)
Warranty	2 years (3 years optional)

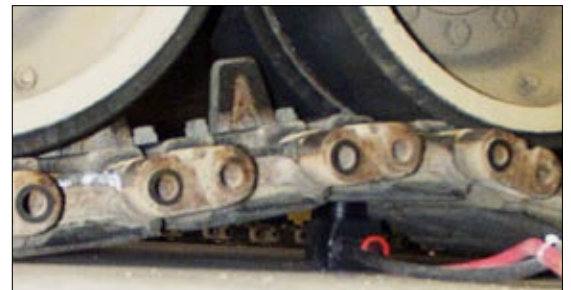

Field Tested

To prove its toughness and dependability, the Cobra NATO Plug was subjected to the harshest abuse. The photo above shows the NATO plug can withstand the weight of a 70 ton M1 Abrams tank. Even after this severe punishment, the plug was still fully functional.