

# TI2000-384

## DC Battery Connector



Power Anytime, Anywhere

The Tesla™ DC Battery Connector is constructed from a rugged combination of advanced composite materials and corrosion-resistant alloys. The result is a weatherproof DC connector that will withstand battlefield conditions and other extreme environments.

Along with highly conductive contact materials, the virtually indestructible design and fast “in-the-field” component replacement make it the last dc connector you will ever need.

### Features:

- Military Standard MS3509
- Rated to 3000 peak amps
- Clamped cable connections
- UV, fuel, fungus, oil, and water resistant
- Tested to withstand 50 G of shock
- Exceeds MIL-STD-810
- Easy component replacement
- Manufactured by Tesla™



Tesla™ Industries, Inc.

[www.teslainsd.com](http://www.teslainsd.com) ♦ [www.tesla1.com](http://www.tesla1.com)

Email: [tesla1@teslainsd.com](mailto:tesla1@teslainsd.com)

**Headquarters:** (302) 324-8910

101 Centerpoint Blvd. New Castle, DE 19720

**Western Regional Office:** (775) 622-8801

9475 Double R Blvd. Suite 2, Reno, NV 89521



The **POWER**  
of  
**RED**™



# Features and Benefits

## Weatherproof Construction

Through a series of strategically placed seals and bushings, the Tesla™ DC Battery Connector is hermetically sealed to lock out rain, snow, sand and other harmful debris.

## Internal Cable Connections

Unlike connectors with cables that are molded directly to the housing, ring terminals (see Figure 1) allow for direct termination inside of the connector. This eliminates the need for cumbersome splices.

## Rugged, Durable, Reliable

Made from virtually indestructible composite materials, the plug housing won't crack, melt, blister, dry-rot or disintegrate. This, in conjunction with corrosion resistant conductors, this insures that the Tesla™ DC Battery Connector will still be in the field long after other connectors have failed.

## Replaceable DC Connector Contacts

Manufactured from highly conductive alloys, the (shown in Figure 2) contacts feature threads that are resistant to damage and ideal for superior torquing and surface contact. Contacts can be easily replaced “in-the-field” without discarding the entire connector.

## Insertion/Extraction Tool

The DC Battery Connector can be easily repaired by replacing the contacts using the Insertion/Extraction Tool pictured in Figure 3. The tool and replacement contacts can be ordered through Tesla™ Customer Service at (302) 324-8910.



Figure 1: Ring Terminal  
Standard stud size: 3/8 inch

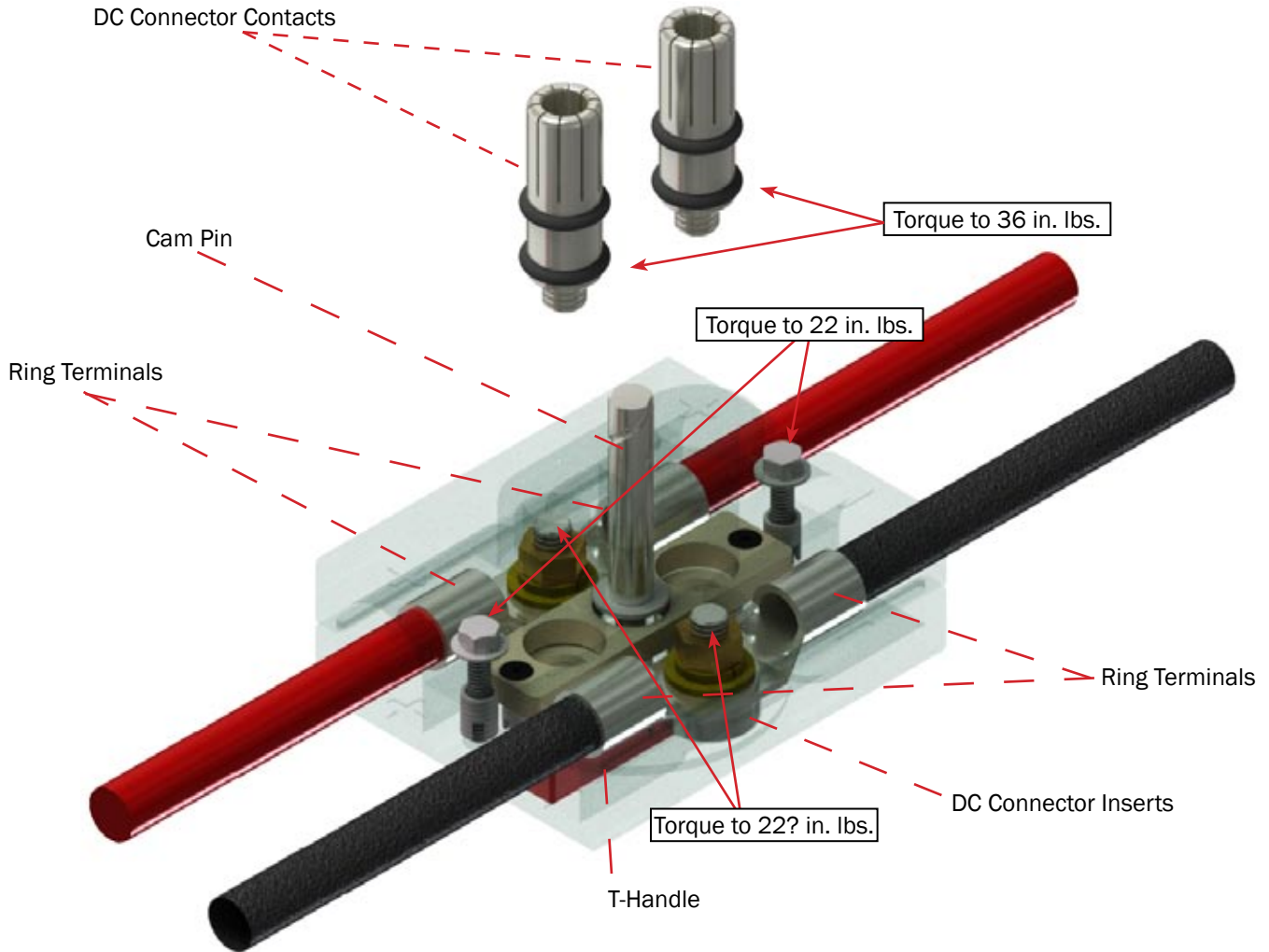

Figure 2: Replacement Contacts: TI2004-336

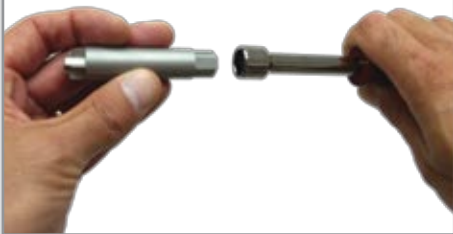

Figure 3: Insertion/Extraction Tool: TI2005-488

# Components - Exploded View



Step 1



Step 2



Step 3



Step 4



## Contact Replacement

**Step 1:** To remove either contact, insert the hex end of the DC Contact Insertion/Extraction Tool into a 1/2 inch socket wrench. Do not use a torque wrench.

**Step 2:** Next, insert the tool into the contact and turn counterclockwise using the wrench.

**Step 3 & 4:** To install a new contact, first apply the Silicone Compound (TI6000-367) to the male threads of the replacement contact. Then use the same tool and screw the contact in clockwise using a 3/8" torque wrench. Set torque to 36 inch-pounds. Be sure to fully insert the tool or the fins will snap off.

# Dimensions and Technical Specifications

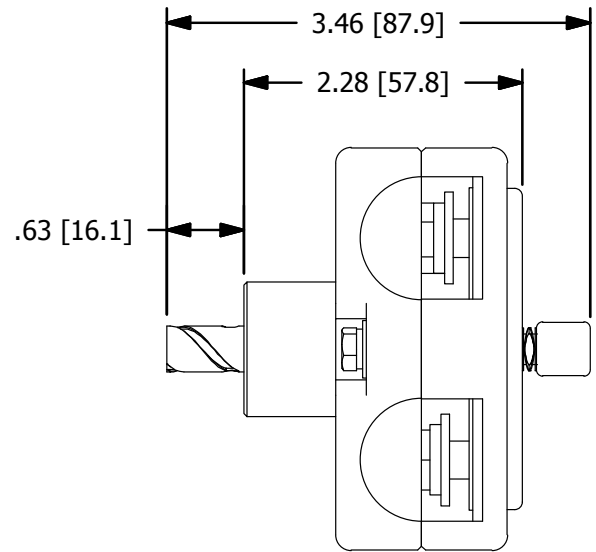
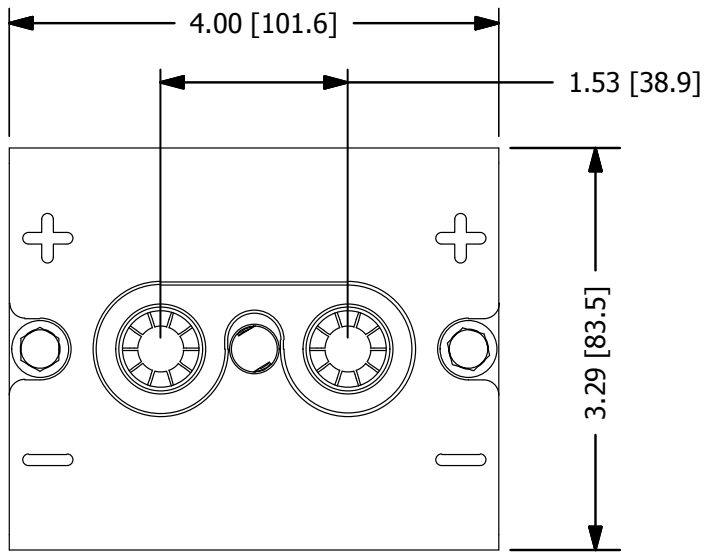

\* All dimensions are in inches [millimeters]

## Technical Specifications:

Number of Contacts	2
Peak Current	3000 A
Storage Temperature	-65°C - 125°C (-85°F - 257°F)
Operating Temperature	-40°C - 110°C (-40°F - 230°F)
Air Gap-leakage Path	0.4" (10.16 mm)
Protection Class	IP20
Rated Current	1500 A
Rated Voltage	18 - 32 Vdc
Inrush Current (@ 28 Vdc)	3000 A
Dielectric Strength	> 6000 Vdc for 1 min. across contacts
Insulation Resistance	4 GΩ w/1kV across contacts
Contact Resistance	< 60 μΩ @ 25°C
Shock	50 G
Vibration	Exceeds MIL-STD-810
Engagement Torque	6 lbs (2.7 kg)
Weight	1.20 lbs ( 0.54 kg)
Warranty	2 years (3 years optional)

